

## VERTICAL TURBINE DIESEL FIRE PUMP | 4000 GPM WITH 12x20 CAST STEEL HEAD | SUBMITTAL

File No: F51.640  
Date: JULY 15, 2013  
Supersedes: F51.640  
Date: AUGUST 15, 2005

Job: \_\_\_\_\_ Representative: \_\_\_\_\_  
 \_\_\_\_\_ Order no.: \_\_\_\_\_ Date: \_\_\_\_\_  
 Engineer: \_\_\_\_\_ Submitted by: \_\_\_\_\_ Date: \_\_\_\_\_  
 Contractor: \_\_\_\_\_ Approved by: \_\_\_\_\_ Date: \_\_\_\_\_

**Model:** 12x18H VTF      **Discharge head:** 12x20 A

**RPM:** 1770 Water lube

**4000 GPM:** \_\_\_\_\_ T.D.H

- FM       UL       NFPA-20 only
- Approval     Construction
- Engine model: \_\_\_\_\_
- Ragd model: \_\_\_\_\_
- Shaft model: \_\_\_\_\_
- Controller model: \_\_\_\_\_

### NOTES

- Dimension based on randolph gear drive. May vary when driver adaptor is required.
- Dimensions are in inches unless otherwise indicated.
- Engine to base mounting and cooling loop to be field installed and plumbed.
- Engine oil & anti freeze/coolant may not be included.
- Gear shipped filled with oil. Check level before installation.
- Refer dwg. no. \_\_\_\_\_ for Engine dimensions.
- Not to be used for construction unless certified.

PRESS RATE	DISCHARGE FLANGE INCH (mm)					
	DA	DC	DD	DF	DG	DK
125 #	19.00 (483)	17.00 (432)	16.50 (419)	12.00 (304)	1.00 (25)	1.25 (32)



NO OF STG'S	DISCHARGE SIZE	RATING	RAGD	AG*	B	C	H*	I*	L	AA
	INCH (mm)		HP	INCH (mm)						
2	12.00 (305)	125	400	36.00 (914)	54.00 (1372)	1.94 (49)	13.75 (349)	21.75 (553)	—	—
2	12.00 (305)	125	500	45.44 (1154)	54.00 (1372)	1.94 (49)	18.75 (476)	28.00 (711)	—	—

\* Dimension based on randolph gear drive. May vary when driver adaptor is required.

**SUBMITTAL**  
4000 GPM

Vertical turbine diesel Fire pump  
4000 GPM with 12x20 Cast Iron Head

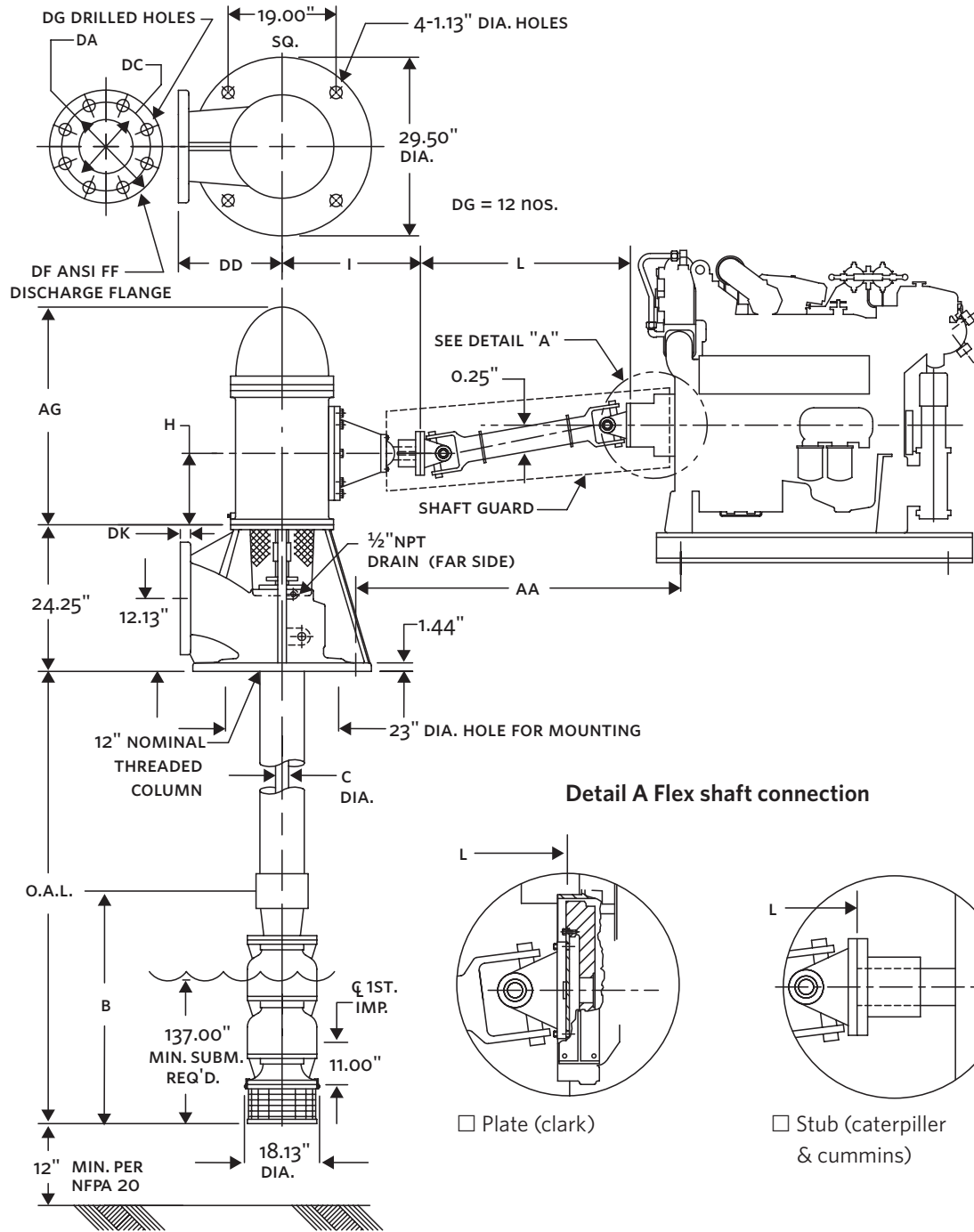

**Detail A Flex shaft connection**

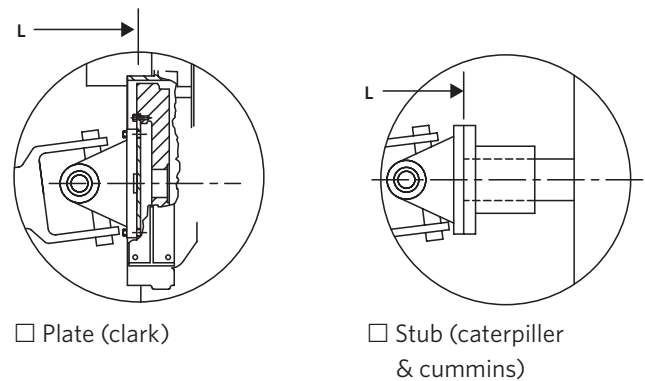

**TORONTO**  
+1 416 755 2291

**BUFFALO**  
+1 716 693 8813

**BIRMINGHAM**  
+44 (0) 8444 145 145

**MANCHESTER**  
+44 (0) 8444 145 145

**BANGALORE**  
+91 (0) 80 4906 3555

**SHANGHAI**  
+86 21 3756 6696

ARMSTRONG FLUID TECHNOLOGY  
ESTABLISHED 1934

ARMSTRONGFLUIDTECHNOLOGY.COM