

# ARMSTRONG®

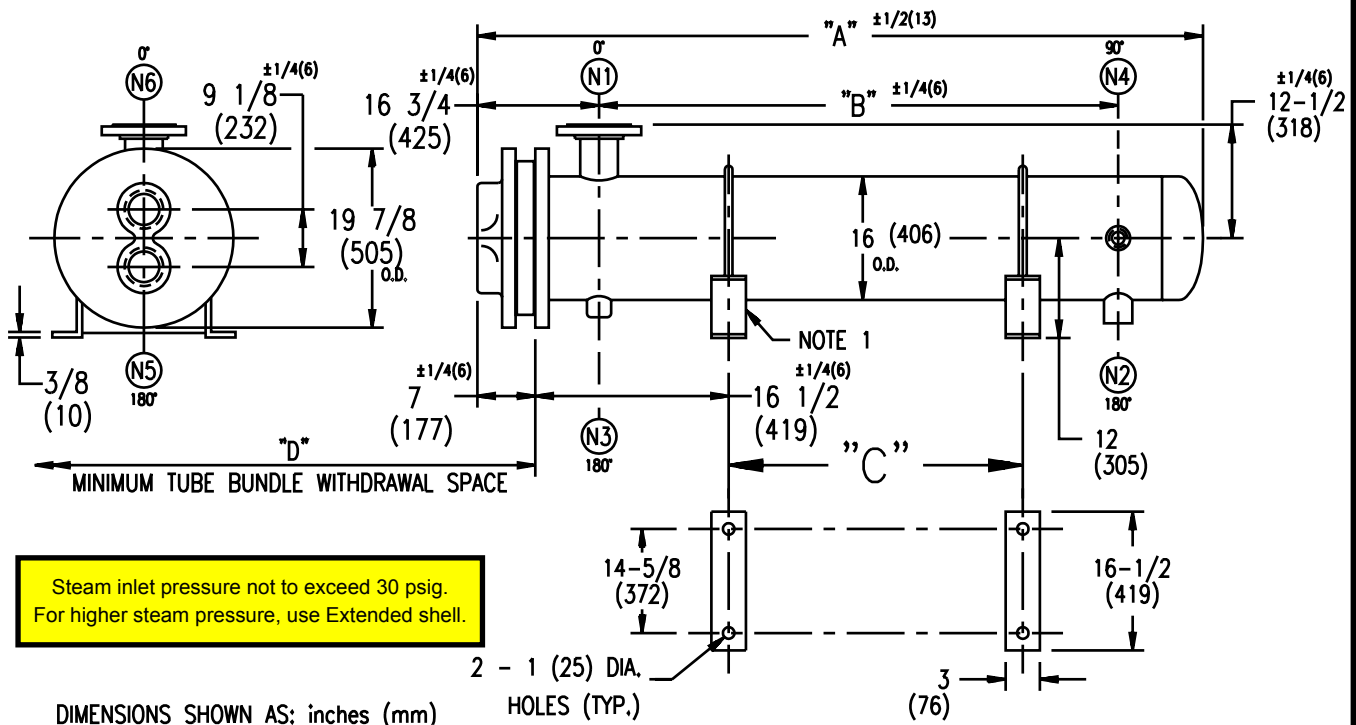

EXCHANGER SIZE	DIMENSIONS											
	A		B		C		D		N1		N2	
	inches	mm	inches	mm	inches	mm	inches	mm	inches	mm	inches	mm
WS-163-2-1	44 1/8	1127	19-3/4	502	6	152	38	965	8	203	2-1/2	64
WS-164-2-1	56 1/8	1432	31-3/4	806	18	457	50	1270	8	203	2-1/2	64
WS-165-2-1	68 1/8	1737	43-3/4	1111	30	762	62	1575	8	203	2-1/2	64
WS-166-2-1	80 1/8	2042	55-3/4	1416	42	1067	74	1880	8	203	2-1/2	64
WS-167-2-1	92 1/8	2346	67-3/4	1721	54	1372	86	2184	8	203	2-1/2	64

NOZZLE SCHEDULE				
SERVICE	MARK	SHELL SIDE	MARK	TUBE SIDE
INLET	(N1)	AS PER TABLE	(N5)	6 (152) NPT
OUTLET	(N2)	AS PER TABLE	(N6)	6 (152) NPT
DRAIN	(N3)	1/2 (13) NPT		
VENT	(N4)	3/4 (19) NPT		

NOTES: 1. SUPPORTS SUPPLIED ONLY IF SPECIFIED ON ORDER.  
 2. NOZZLE SIZES SHOWN ARE RECOMMENDED FOR MAXIMUM EXCHANGER LIFE.  
 3. FABRICATED TO ASME CODE SECTION VIII DIVISION 1 AND LATEST ADDENDA.  
 4. DRAWING IS NOT TO SCALE.  
 5. ALL DIM'S ±1/8 (3) UNLESS OTHERWISE SHOWN.

DESIGN CONDITIONS				
	SHELL		TUBES	
DESIGN PRESSURE	150 PSIG	1034 KPa	125 PSIG	862 KPa
DESIGN TEMPERATURE	375 °F	191 °C	375 °F	191 °C
MIN. DESIGN METAL TEMP.	40 °F	4.4 °C	40 °F	4.4 °C
HYDRO. TEST PRESSURE	225 PSIG	1551 KPa	250 PSIG	1723 KPa
CONTENTS	STEAM		WATER	

CUSTOMER:  
 LOCATION:  
 ENGINEER:  
 ORDER No.:  
 PROJECT/JOB:  
 LOCATION:  
 TAG: (QUOTE # )

TITLE G.A. 150 LB. WS SERIES HEAT EXCHANGERS	A R M S T R O N G				NUMBER WS-16-2P-1(8)	REV.
DATE: 12/01/94 BY: D.C.R.	TORONTO - CANADA TEL: (416) 755-2291	MONTREAL - CANADA TEL: (514) 421-2424	BUFFALO - N. Y. TEL: (716) 693-8813	COLCHESTER - U.K. TEL: (44) 120-657-9491		